



For Irrigation and Water Systems



MAIS VALVE BOX



For Irrigation and Water Systems

MAIS VALVE BOX



	6" Round	10" Round	1419	1220 - 1320	1324
MAIS Standard Series	✓	✓	✓	✓	✓
MAIS Pro Series				✓	✓



For Irrigation and Water Systems

Standard Series

Round Valve Box 610-6"

Box Options	Black, Green, Sand, Purple
Lid Options	ICV (black/green/sand/brown), Water (green), Sewer (green), Reclaimed (purple/black)



Round Valve Box 910-10"

Box Options	Black, Green, Sand, Purple
Lid Options	ICV (black/green/sand/brown), Water (green), Sewer (green), Reclaimed (purple/black)



STD Valve Box 1419-12"

Box Options	Black, Green
Lid Options	ICV (black/green/sand/brown), Water (green), Sewer (green), Reclaimed (purple/black)



Valve Box Jumbo 1320-20"

Box Options	Black, Green
Lid Options	ICV (black/green/sand/brown), Water (green), Sewer (green), Reclaimed (purple/black)



Valve Box Super Jumbo 1324-24"

Box Options	Black, Green
Lid Options	ICV (black/green/sand/brown), Water (green), Sewer (green), Reclaimed (purple/black)





For Irrigation and Water Systems

SERIES 610 - 6" ROUND VALVE BOX

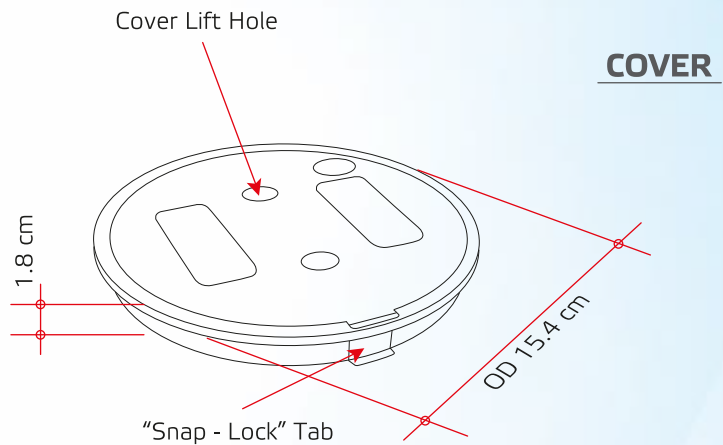

SPECIAL FEATURES

- Ideal for Residential Single Valve Operation
- Economical
- Twist Lock Cover
- High Top Load Strength
- Weight 0.55 kg
- U.V. Resistant
- Easy Storage
- Pipe cut outs allows for quick and easy installment

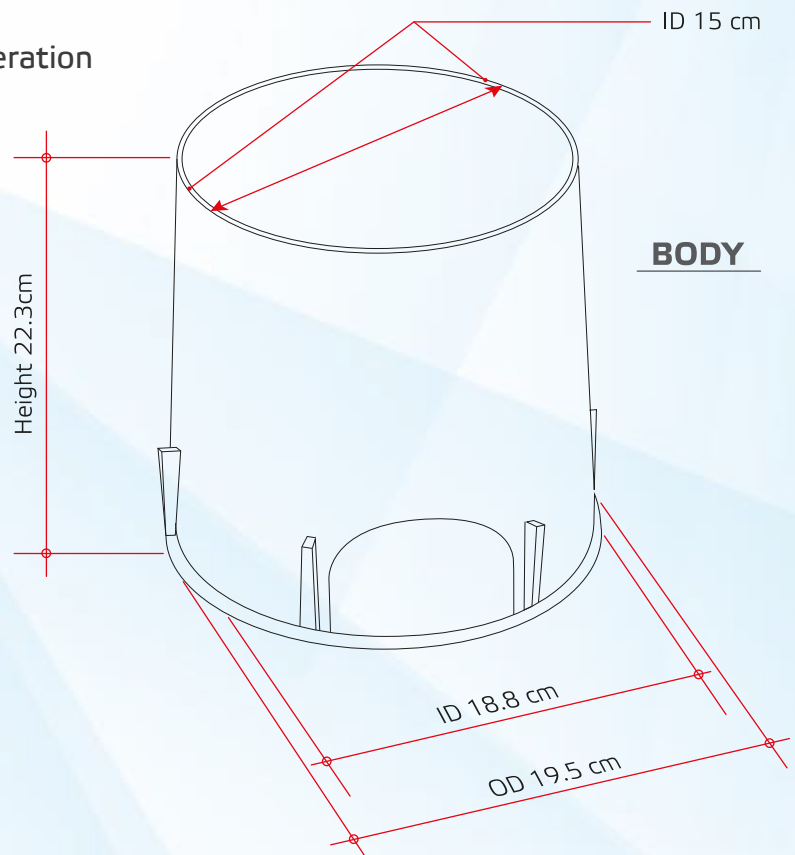



For Irrigation and Water Systems

SERIES 910 - 10" ROUND VALVE BOX

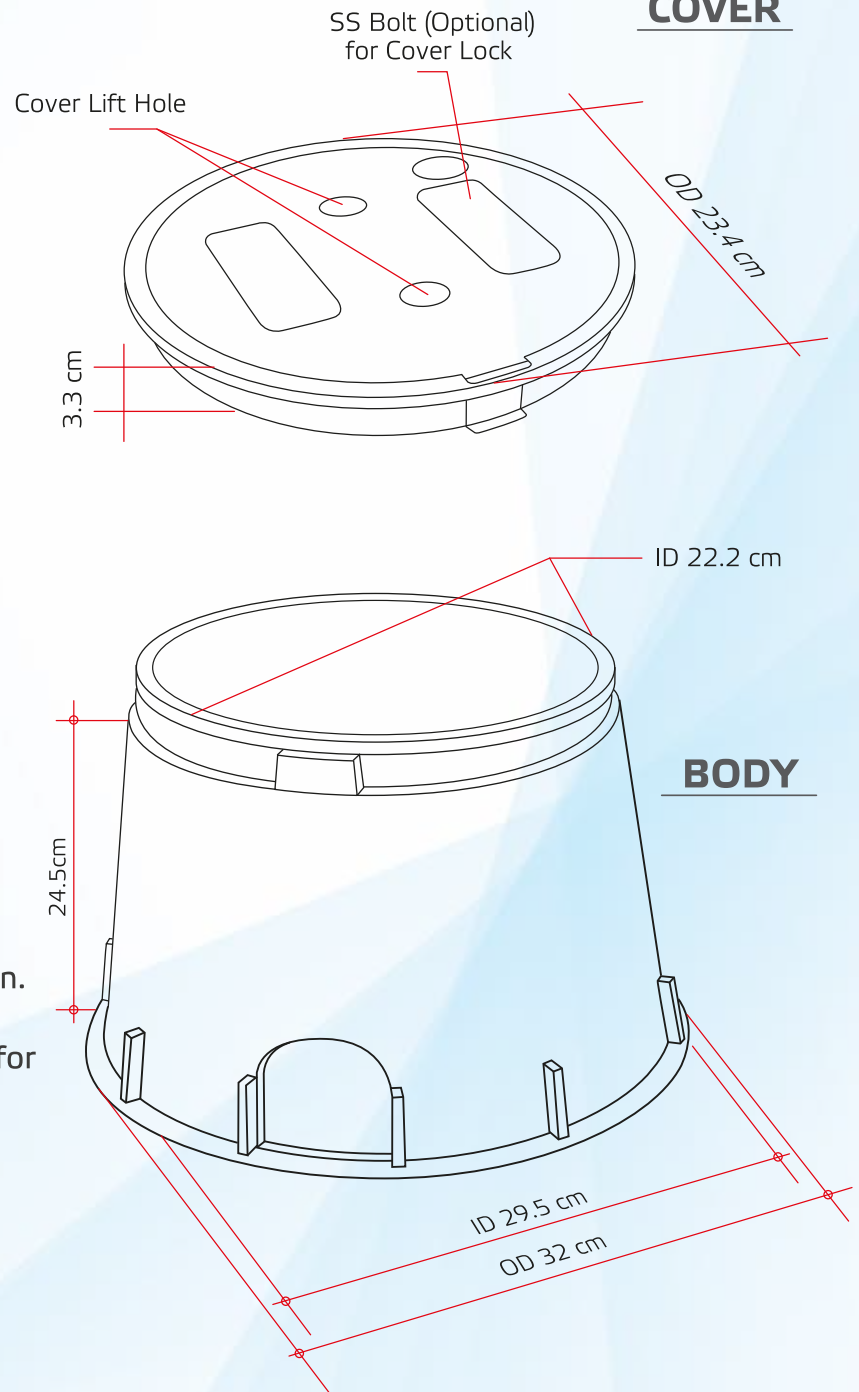
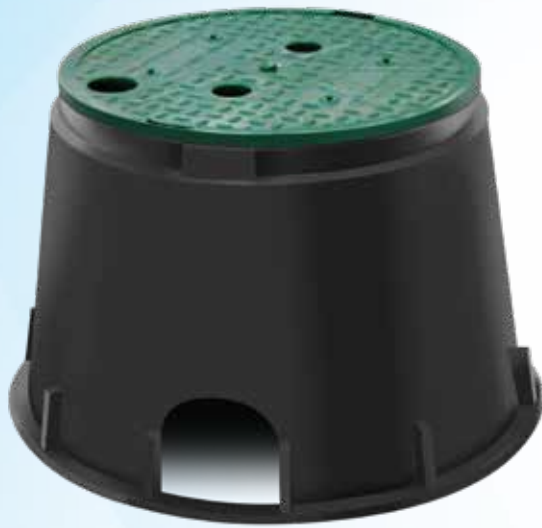

SPECIAL FEATURES

- A durable round valve box ideal for commercial and residential installation.
- Round valve box have extra support for strong load strength
- Original twist lock design cover
- Weight 1.28 kg
- U.V. Resistant
- Easy Storage
- Pipe cut outs allows for quick and easy installment



For Irrigation and Water Systems

SERIES 1419 - 12" Standard Rectangular Valve Box

SPECIAL FEATURES

- Surface Mounted Box
- Cover complies with the slip resistance Requirements of SASO Standards.
- U.V. Resistant
- Weight 3.8 Kg
- Easy Storage
- Stainless Steel Bolt and Nut (Optional)





For Irrigation and Water Systems

SERIES 1419 - 12" Standard Rectangular Valve Box General Details

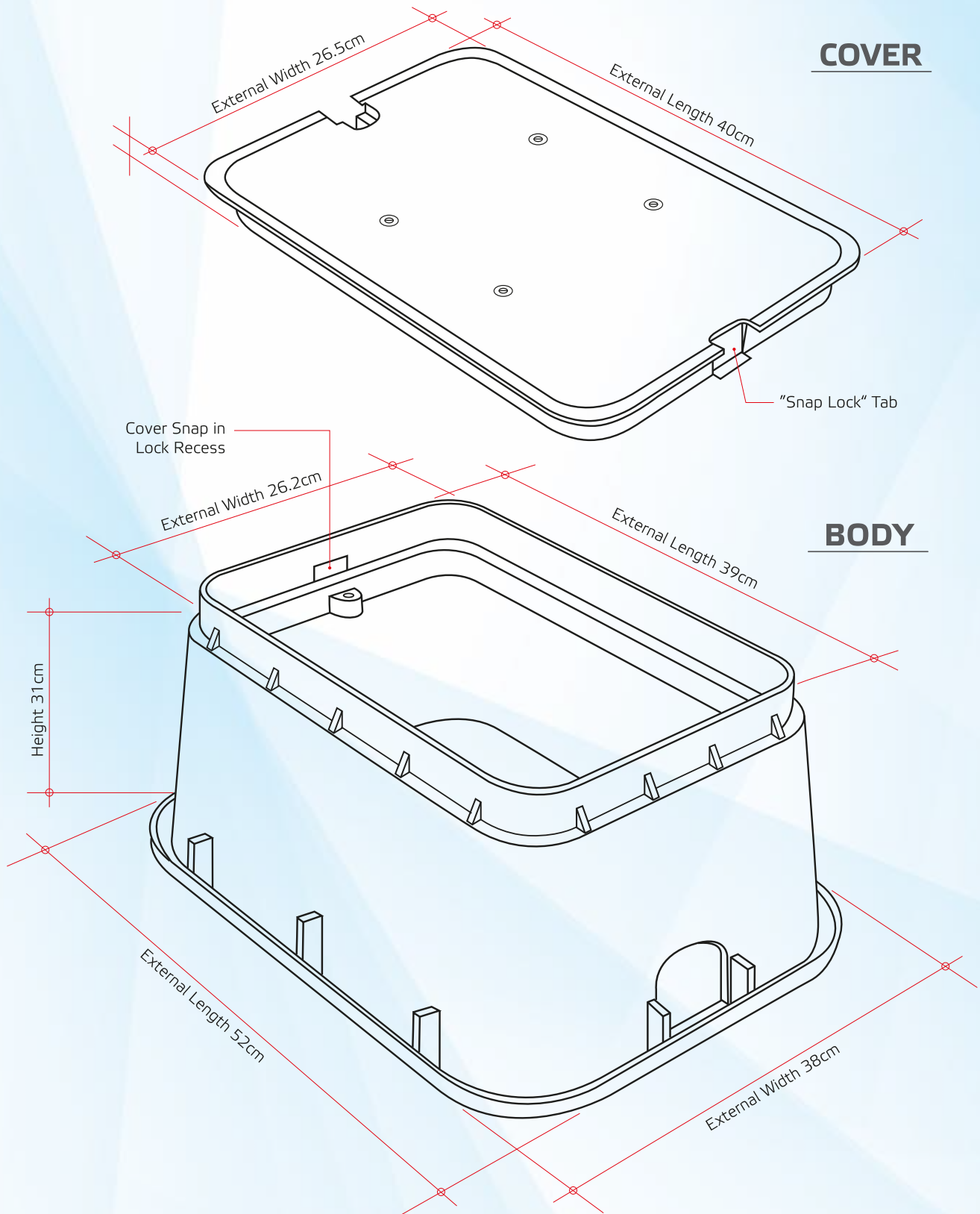



For Irrigation and Water Systems

SERIES 1320 - 20" Jumbo Rectangular Valve Box General Details

SPECIAL FEATURES

- Surface Mounted Box
- Cover complies with the slip resistance Requirements of SASO Standards.
- Ultra Violet Light
- Moisture, Weather, Acid & Alkalies Chemical Action Soil Resistance
- Weight 6.8 Kg
- Easy Storage
- Stainless Steel Bolt and Nut (Optional)

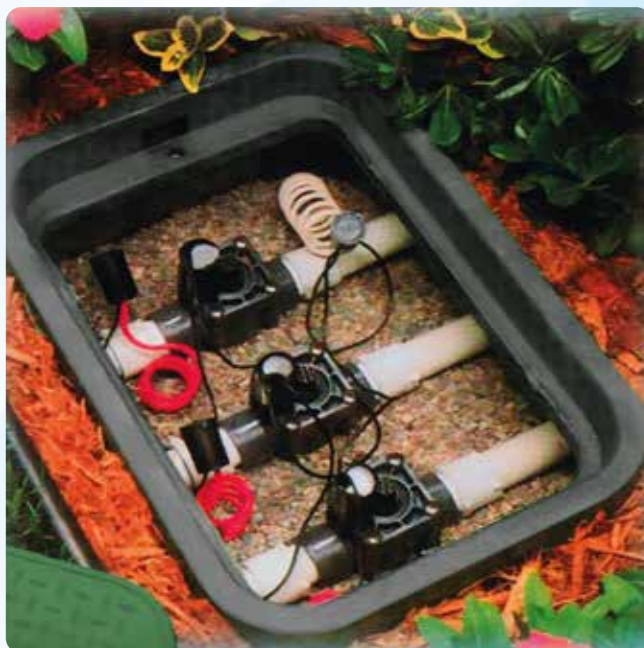



For Irrigation and Water Systems

SERIES 1320 - 20" Jumbo Rectangular Valve Box General Details

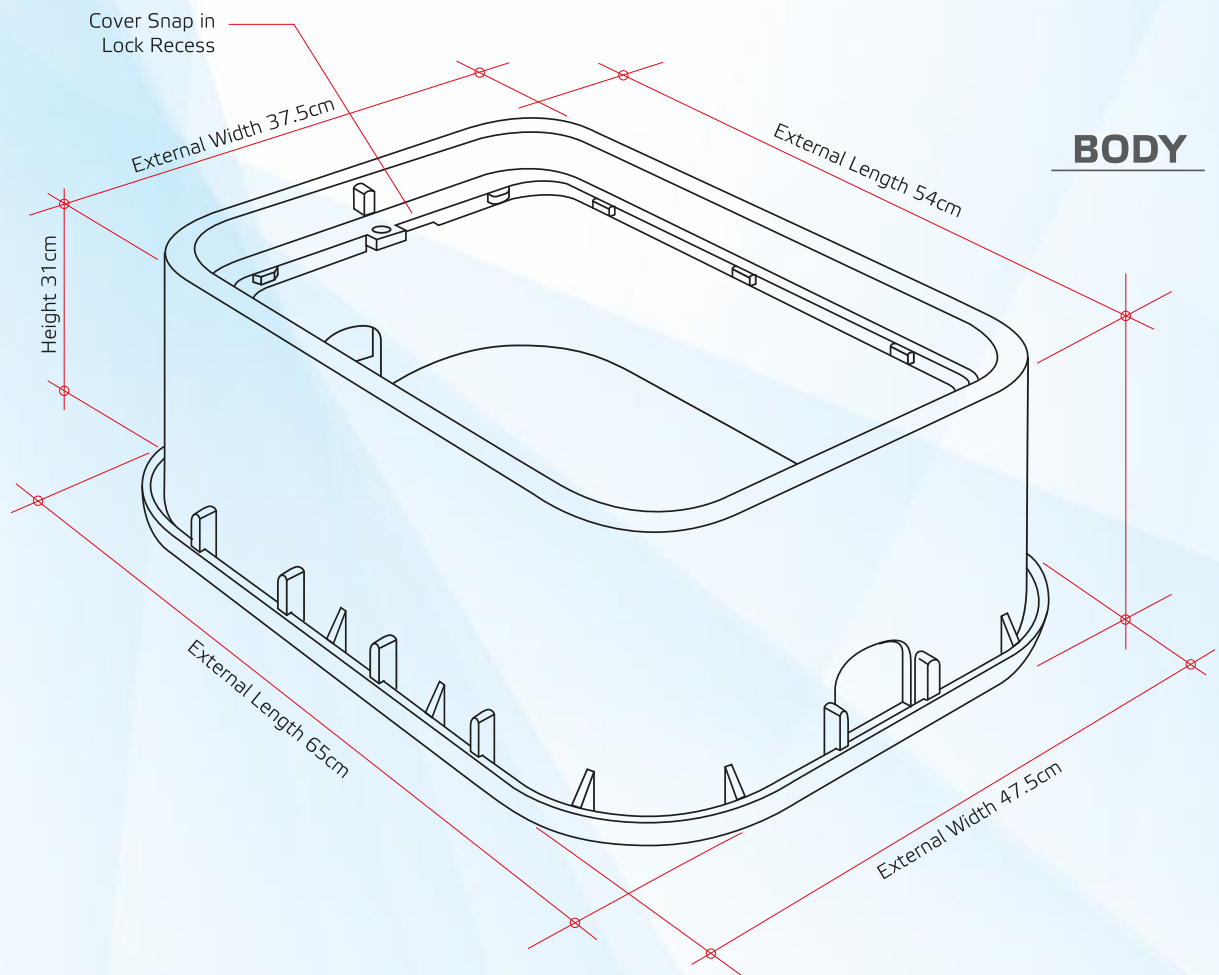
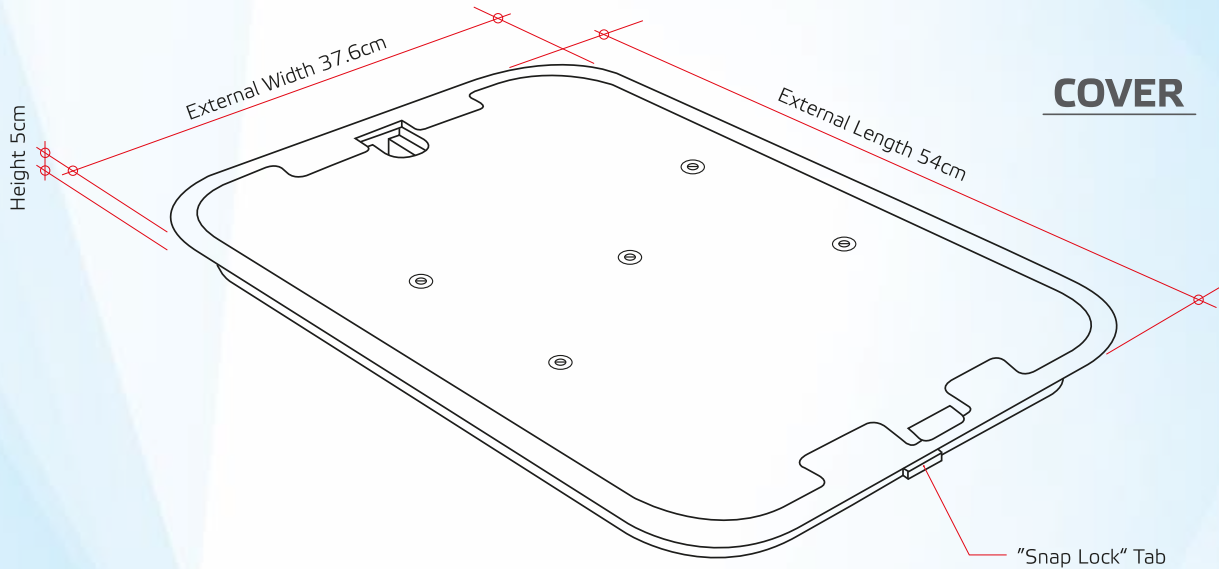



For Irrigation and Water Systems

SERIES 1324-24" Super Jumbo Rectangular Valve Box General Details

SPECIAL FEATURES

- Surface Mounted Box
- Cover complies with the slip resistance Requirements of SASO Standards
- Moisture, Weather, Acid & Alkalies Chemical Action Soil Resistance
- Weight 14.50 Kg
- Easy Storage
- Stainless Steel Bolt and Nut (Optional)





For Irrigation and Water Systems

SERIES 1324-24" Super Jumbo Rectangular Valve Box General Details

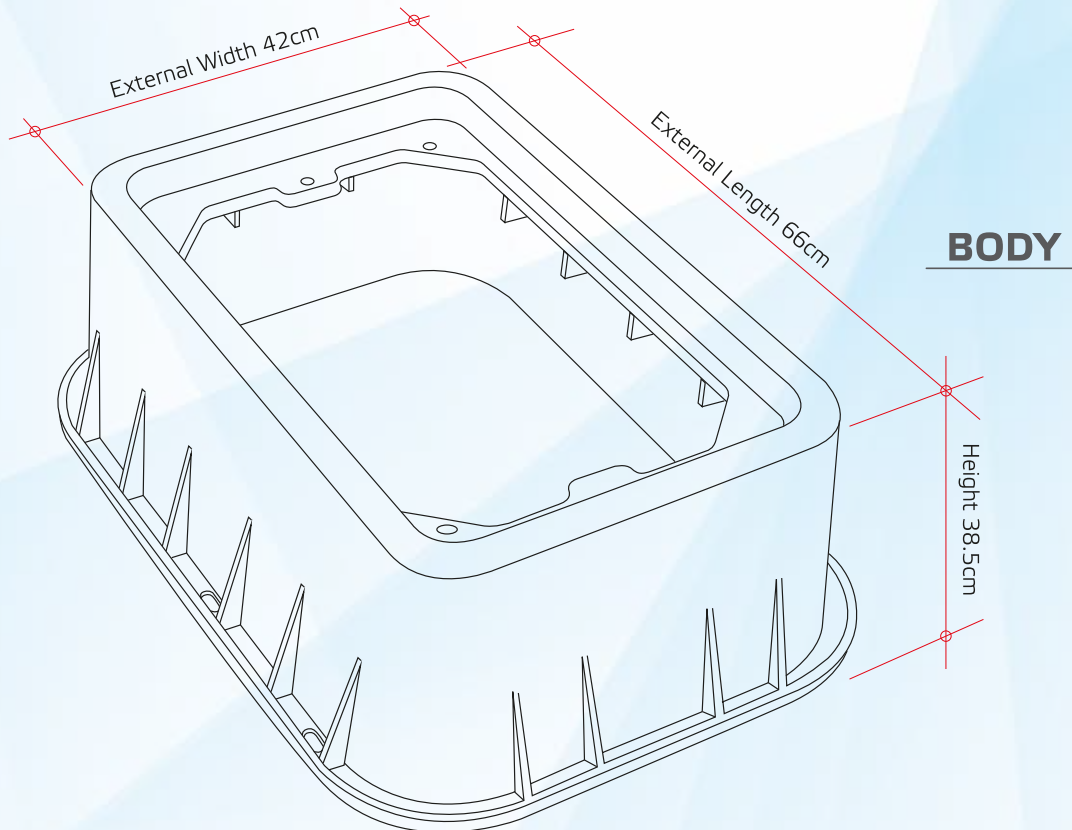
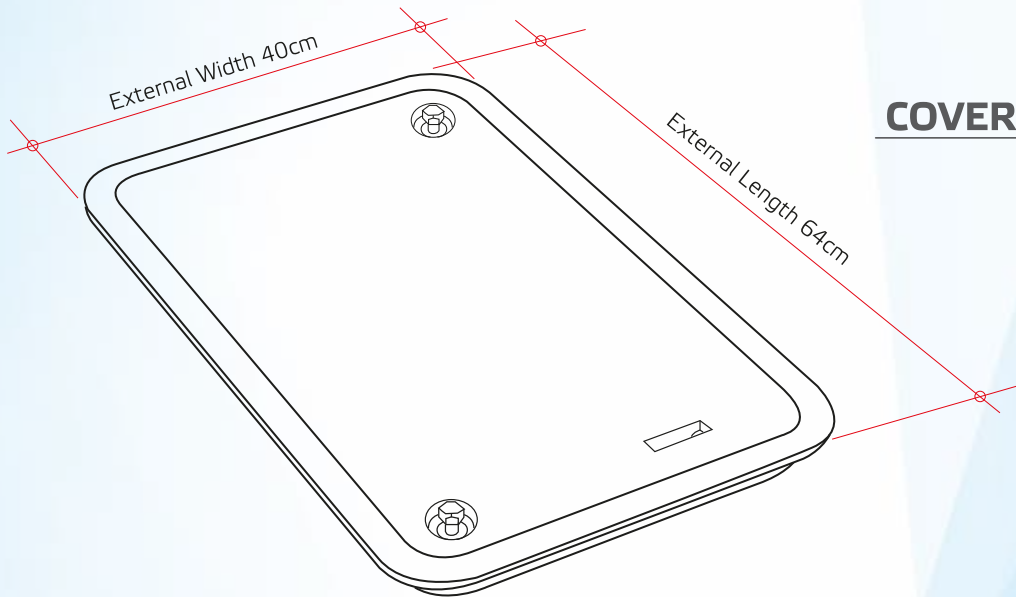



For Irrigation and Water Systems

MAIS PRO VALVE BOXES

JUMBO 1220-14" PRO

Box Options	Black, Green, Sand, Gray, Purple
Lid Options	ICV (black/green/sand/brown), Water (black/green), Sewer (green), Reclaimed (black/green/purple), Electric (gray/green)



SUPER JUMBO 1324-24" PRO

Box Options	Black, Green, Sand, Gray, Purple
Lid Options	ICV (black/green/sand/brown), Water (black/green), Sewer (green), Reclaimed (black/green/purple), Electric (gray/green)





For Irrigation and Water Systems



DESCRIPTION	BOX COLOR	COVER COLOR	COVER MARKING
BOX & COVER COMBINATIONS			
12 5/8" TALL BOX WITH OVERLAPPING BOLT-DOWN COVER	BLACK	GREEN	ICV

PHYSICAL PROPERTIES OF PP	ASTM TEST METHOD	TEST RANGE MAIS
TENSILE STRENGTH YIELD	D-638	3,400 – 4,400 PSI
FLEXURAL MODULUS	D-790	140,000 – 200,152 PSI
COMPRESSIVE STRENGTH	D-695	3,340 – 4,600 PSI
IMPACT STRENGTH, IZOD	D-256	1.5 – 15 FT. LBS/IN
DUROMETER HARDNESS, TYPE D	D-2240	63 – 67
DEFLECTION TEMPERATURE @ 66 PSI STRESS	D-648	150 – 212 ° F
SPECIFIC GRAVITY	D-792	0,941 – 0.965



For Irrigation and Water Systems

1220 - 14" MAIS PRO - VALVE BOX

Box Material : Polypropylene (PP)
 Cover Material : Polypropylene (PP)
 Box Weight : 5.4 kg
 Lid Weight : 2.0 kg
 Total Weight : 7.4 kg



Includes 3/8 stainless steel bolt
 Made in high resistance Polypropylene (PP) for long life
 U.V. protected
 Made in KSA - Mais Factory
 Second Industrial Area, Riyadh
 Warranty : 10 Years
 Load Rating : Pedestrian & Lawn Care Equipment

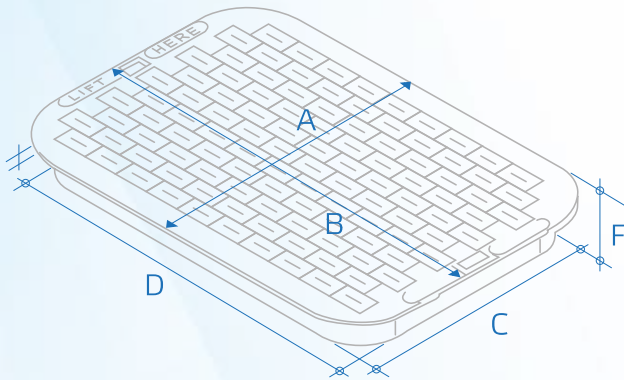

DESCRIPTION	
A. Top View	38.5
B. Top Length	54.30
C. Bottom Width	32
D. Bottom Length	49.4
E. Rim Thickness	2.9
F. Overall Height	3.6

DESCRIPTION	
A. Top Inside Width	33.30
B. Top Inside Length	50
C. Top Outside Width	36
D. Top Outside Length	54.5
E. Bottom Outside Width	51
F. Bottom Outside Length	69
G. Height	31.5
H. Bottom Inside Width	45
I. Bottom Inside Length	65

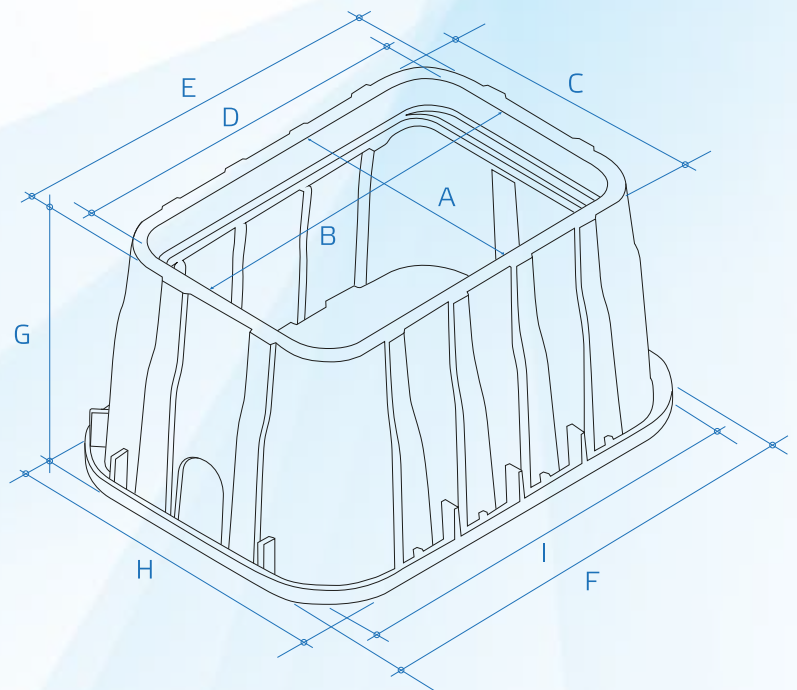



For Irrigation and Water Systems

1324 - 24" MAIS PRO - VALVE BOX

Box Material : Polypropylene (PP)
 Cover Material : Polypropylene (PP)
 Box Weight : 11kg
 Lid Weight : 4 kg
 Total Weight : 15 kg



Includes 3/8 stainless steel bolt
 Made in high resistance Polypropylene (PP) for long life
 U.V. protected
 Made in KSA - Mais Factory
 Second Industrial Area, Riyadh
 Warranty : 10 Years
 Load Rating : Pedestrian & Lawn Care Equipment

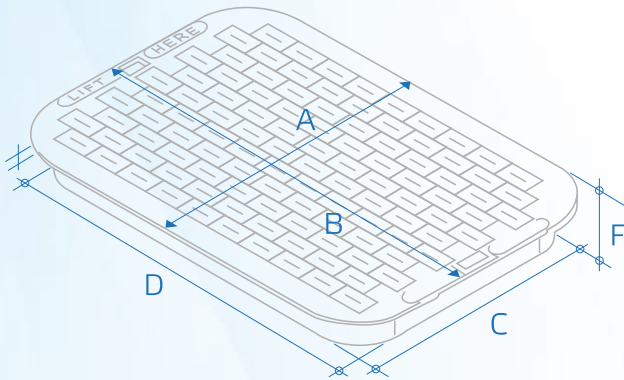

DESCRIPTION	
A. Top View	33
B. Top Length	57
C. Bottom Width	32
D. Bottom Length	49
E. Rim Thickness	2.9
F. Overall Height	3.6

DESCRIPTION	
A. Top Inside Width	33
B. Top Inside Length	57
C. Top Outside Width	45
D. Top Outside Length	69
E. Bottom Outside Width	60
F. Bottom Outside Length	84
G. Height	38
H. Bottom Inside Width	49
I. Bottom Inside Length	73

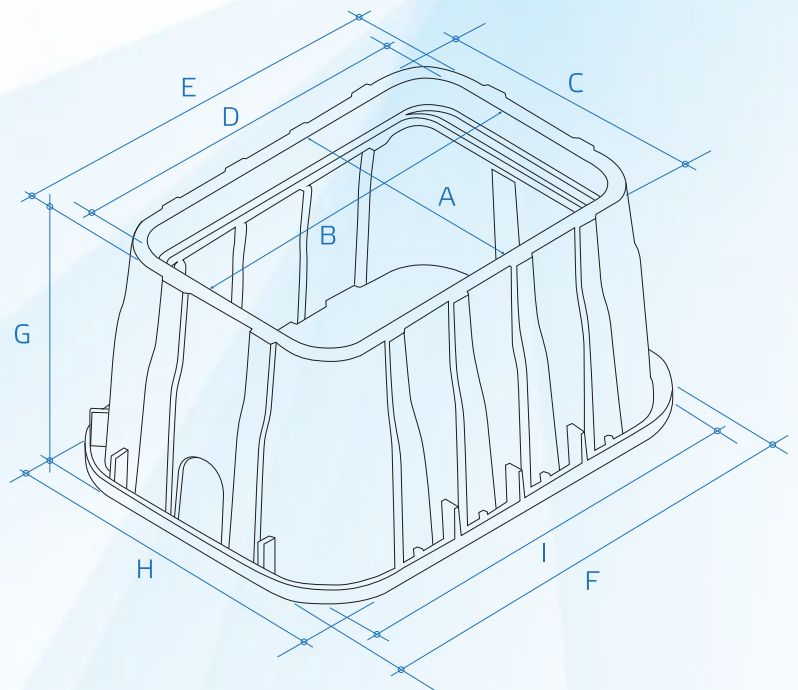



For Irrigation and Water Systems



P.O.Box 42801, Riyadh 11551 - Saudi Arabia
Tel.: +966 11 2652300 - Fax : +966 11 2651344
email: mais@maisirrig.com.sa
www.maisirrig.com.sa